

Component Part Numbers:

- 1) ETC-12 Left/Right end cap
- 2) WGA-12 Aluminum retainer in two pieces,  
identical upper and lower half sections
- 3) OTC-12 Outside corner
- 4) WGB-8 Impact cushion
- 5) Field mitered corner
- 6) Snap-on cover WGV-12-12-XXX  
standard texture and accent grooves

**Step 1:** The aluminum retainer for this wall guard is provided in two identical half sections, one section will serve as the lower half of the retainer and the other as the top. Snap a chalk line to locate the centerline of the wall guard, see **fig 1**, this is where the two half sections will meet.

**Important:** Store material in a clean dry place where the temperature is maintained above 50°F (10°C). Walls and rooms should be maintained at a minimum of 65°F (18°C) for at least 48 hours prior to installation. Acclimate materials to normal building conditions for at least 24 hours before cutting and installing.

**Step 2:** Cut two half sections of aluminum to the length required for each section of wall guard. See **Cutting Adjustment Diagrams and Schedule** for adjustments to aluminum retainer length at end caps and outside corners. Refer to **Minimum Layout Configurations** for additional information. Aluminum should be mitered to accommodate outside corners that are not 90° and all inside corners.

**Important:** All cuts must be square and deburred.

**Step 3:** Pre-drill clearance holes in each half section of retainer using a #15 (.180") bit for #8 fastener or a #7 (.201") bit for #10 and 3/16" fasteners. Locate mounting holes at 32" on center along each retainer as shown in **fig 2**. If necessary adjust spacing to accommodate studs. Do not pre-drill at locations that will interfere with installation of molded accessories.

*Note:* Drill point fasteners may be used without pre-drilling aluminum on drywall installations having continuous metal backer or studs. Continue to pre-drill at locations where no backing or stud is available.

**Step 4:** Pre-drill for attachment of molded accessories by inserting accessory in end of retainer. Press firmly to ensure molded part is seated squarely against the aluminum.

**Important:** Aluminum retainer half sections must be held together while locating mounting holes for end caps and outside corners. To ensure proper fit with snap-on cover, accessories must be located with respect to both alignment ribs simultaneously, see **fig 3**. In drywall installations accessory mounting holes may be drilled after the aluminum is in place.

*Drywall Installation:* Using the accessory as a template pre-drill clearance holes in the aluminum for mounting through to metal backer or stud, see **steps 5 and 6**, or pre-drill pilot holes using #29 (.136") bit for #8 fastener or a #21 bit (.159") for #10 fastener for attaching accessories directly to aluminum, see **fig 3**.

*Masonry Installation:* Using the accessory as a template pre-drill clearance holes in the aluminum at mounting locations, see **fig 3**.

**Step 5:** Fasten aluminum retainer to wall using hardware listed below. Align top edge of the lower half section with chalk line and secure in place. Install the top half section aligned at ends with the lower section and against the lower section lengthwise along the chalk line, see **fig 5**.

**Important:** Begin installation of aluminum at corners allowing for molded accessories. Use the appropriate accessory as a spacing template. See **Cutting Adjustment Diagrams and Schedule** for additional information. Do not fasten through holes pre-drilled for installation of molded accessories until accessories are installed in **step 6**.

*Drywall Installation:* Fasten aluminum retainer to wall using hardware listed below. If it is necessary to install fasteners in locations where there is no metal backing or stud use pre-drilled aluminum as a template to mark and drill wall for Toggler® brand toggle bolts or plastic Alligator® insert in accordance with instructions provided with hardware.

*Masonry Installation:* Using the pre-drilled aluminum as a template, mark and drill the wall at all pre-drilled holes to accept plastic Alligator® insert or 3/16" Tapcon® or similar fastener. Drill in accordance with instructions provided with hardware.

**Suggested hardware :**

- Drywall with metal backing : #8 or #10 Drill point drywall screw or #8 or #10 drill point pan head or hex washer head sheet metal screw.
- Drywall without stud or backing : Plastic Alligator® insert with #8 or #10 pan head or hex washer head sheet metal screw or 3/16" Toggler® brand toggle bolts with pan head machine screw.
- Masonry : Plastic Alligator® insert with #8 or #10 pan head or hex washer head sheet metal screw or 3/16" hex washer head Tapcon®.

**Step 6:** Secure accessory components in place using hardware selected in **step 5**.

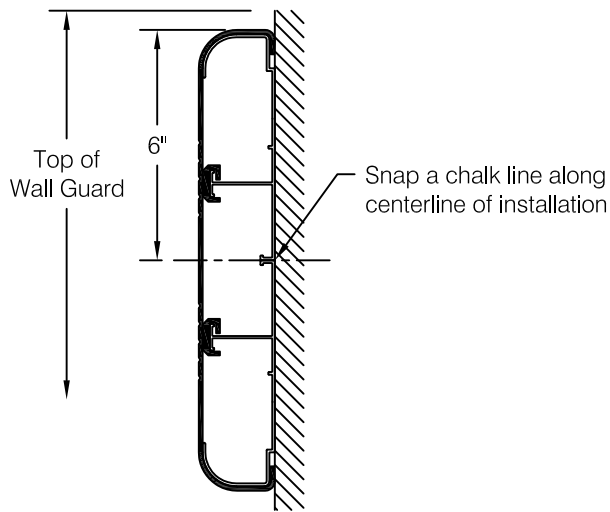
*Caution:* A flat washer at accessory mounting tabs is recommended to prevent damage to molded part caused by excessive tightening of the fastener.

**Step 7:** Install the flexible impact cushion by hooking it over the "T" support provided in each retainer, see **fig 4**. Install impact cushions with "hook" toward the top of the retainer.

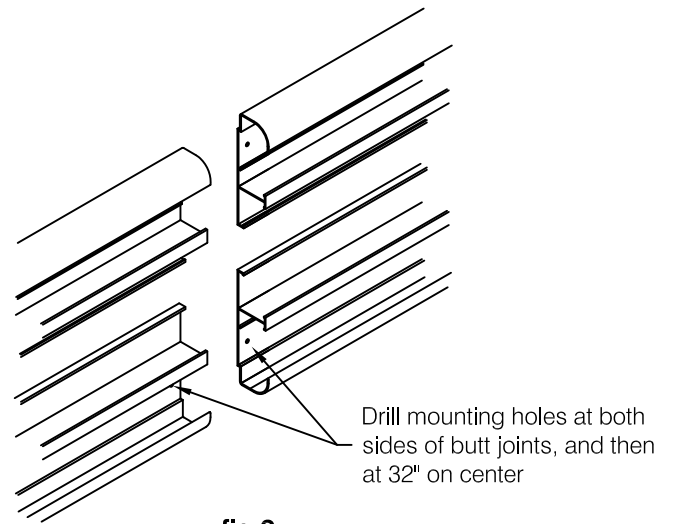
**Step 8:** Measure between accessories and cut the vinyl cover accordingly. Miter cut the cover for all angles and corners not accommodated by the molded accessories.

**Important:** The covers have directional arrows printed on the reverse side. The covers must be installed so that all arrows point in the same direction. To reduce potential confusion arrows should point upward as noted in the printing. As the covers are cut for installation the printing may not remain on all cut lengths. Be sure to mark the back of these lengths with the correct orientation information. All cuts must be square and deburred.

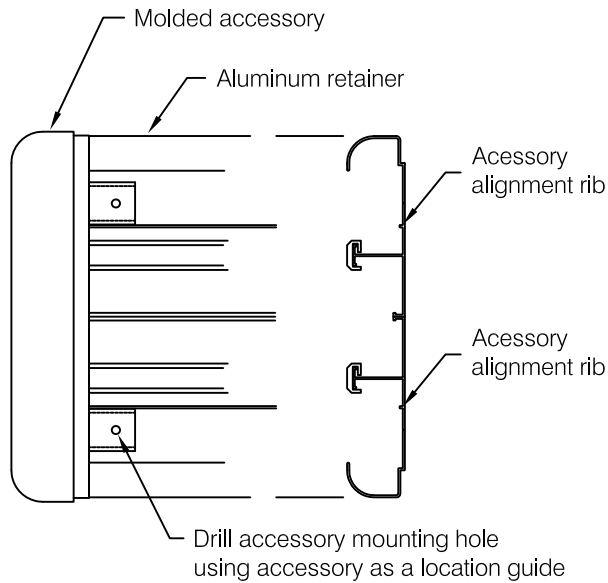
**Step 9:** Snap the cover in place over the aluminum retainer. Install cover to span any butt joints in retainer.



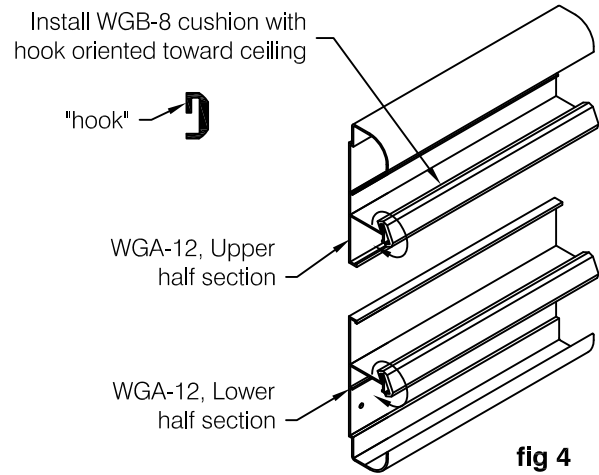
**fig 1**



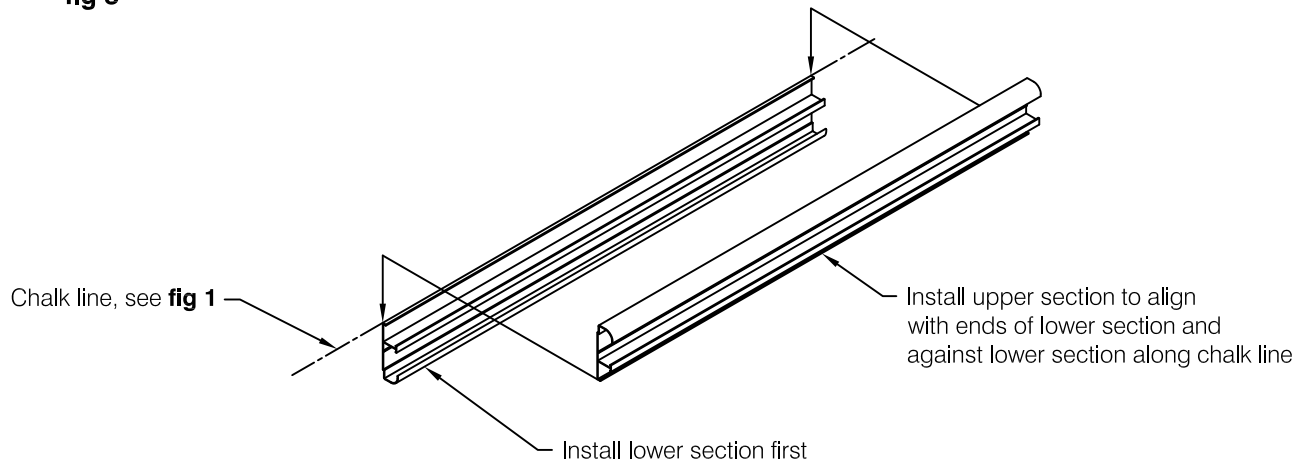
**fig 2**



**fig 3**

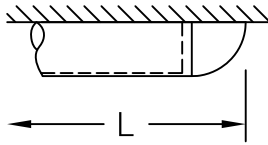


**fig 4**

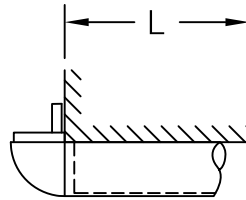


**fig 5**

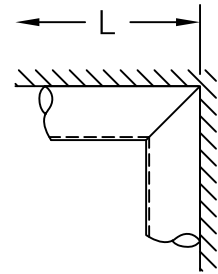
# Cutting Adjustment Diagrams and Schedule



End Cap



Outside Corner



Inside Corner

	Aluminum Retainer	Vinyl Cover
End Cap	L - 2 1/2"	L - 2"
Outside Corner	L - 1/2"	L - 0"
Inside Corner	L - 0" (field miter)	L - 0" (field miter)

Important: install aluminum retainer and molded accessories before cutting the snap-on cover.

## Minimum Layout Configurations

