

1500i/1500iW

Wall Guard

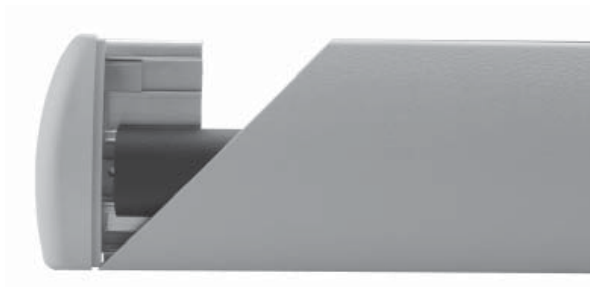

1500i



1500iW

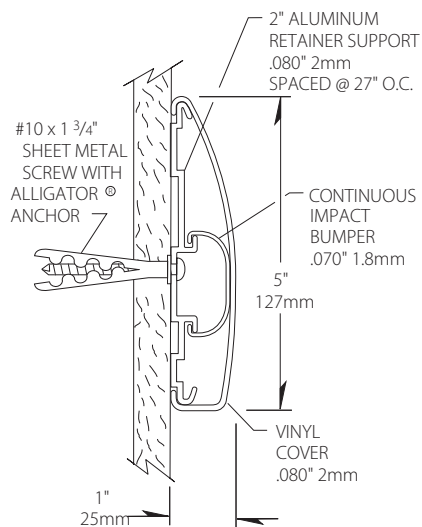

- 5" (127mm) of wall protection, extends 1" (25mm) from wall
- Mounted on an abbreviated aluminum retainer
- .080" (2mm) thick, scratch and stain resistant rigid vinyl cover
- Manufactured in 12' standard lengths
- All mounting fasteners are included with each order
- 1500iW Model - Manufactured with woodland pattern full wrap. 1500iW includes black reveals for end caps and corners.
- Meets the most rigorous standards and criteria of chemical emissions as prescribed by the GREENGUARD Environmental Institute
- Has been tested and meets GREENGUARD Environmental Institute's and the state of California's requirements for low emitting products as tested by Air Quality Sciences
- Has been tested and meets the GREENGUARD Children & School chemical emissions levels



IPC.347/REV.7

1500i/1500iW Wall Guard

Suggested Specifications

PART 1 - GENERAL

1.01 SUMMARY

A. Wall guard system for wall protection and decoration

1.02 SECTION INCLUDES

A. 1500i/1500iW Infinity System Wall Guards

1.03 REFERENCES

A. American Society for Testing and Materials (ASTM)

B. National Building Code of Canada (NBC)

C. National Fire Protection Association (NFPA)

D. Society of Automotive Engineers (SAE)

E. Underwriters Laboratory (UL)

F. Underwriters Laboratory of Canada (ULC)

G. Uniform Building Code (UBC)

1.04 SYSTEM DESCRIPTION

A. Performance Requirements: Provide Wall Guard Systems that conform to the following requirements of regulatory agencies and the quality control of IPC Door and Wall Protection Systems, InPro Corporation.

1. Fire Performance Characteristics: Provide UL Classified wall guards conforming with NFPA Class A fire rating. Surface burning characteristics, as determined by UL-723 (ASTM E-84), shall be flame spread of 10 and smoke development of 350-450. Provide ULC (Canada) listed wall guards conforming to the requirements of the National Building Code of Canada 2010, Subsection 3.1.13. Surface burning characteristics, as determined by CAN/ULC-S102.2, shall be flame spread of 15 and smoke developed of 35.

2. Self Extinguishing: Provide wall guards with a CCI classification, as tested in accordance with the procedures specified in ASTM D-635-74, Standard Test Method for Rate of Burning and/or Extent and Time of Burning of Self-Supporting Plastics in a Horizontal Position, as referenced in UBC 52-4-1988.

3. Impact Strength: Provide rigid vinyl profile materials that have an Impact Strength of 30.2 ft-lbs./inch of thickness as tested in accordance with the procedures specified in ASTM D-256-90b, Impact Resistance of Plastics.

4. Chemical and Stain Resistance: Provide wall guards that show resistance to stain when tested in accordance with applicable provisions of ASTM D-543.

5. GREENGUARD Certified: Provide GREENGUARD Certified material. Profiles shall meet the requirements of GREENGUARD Certification Standards for Low-Emitting Products and GREENGUARD Product Emission Standard for Children & Schools.

6. Fungal and Bacterial Resistance: Provide rigid vinyl that does not support fungal or bacterial growth as tested in accordance with ASTM G-21 and ASTM G-22.

7. Color Consistency: Provide components matched in accordance with SAE J-1545 -(Delta E) with a color difference no greater than 1.0 units using CIE Lab, CIE CMC, CIE LCh, Hunter Lab or similar color space scale systems.

1.05 SUBMITTALS

A. Product Data: Manufacturer's printed product data for each type of wall guard specified.

B. Detail Drawings: Mounting details with the appropriate fasteners for specific project substrates.

C. Samples: Verification samples of wall guard, 8"(203mm) long, in full size profiles of each type and color indicated.

D. Manufacturer's Installation Instruction: Printed installation instructions for each wall guard.

1.06 DELIVERY, STORAGE AND HANDLING

A. Deliver materials in unopened factory packaging to the

jobsite

B. Inspect materials at delivery to assure that specified products have been received.

C. Store in original packaging in a climate controlled location away from direct sunlight.

1.07 PROJECT CONDITIONS

A. Environmental Requirements: Products must be installed in an interior climate controlled environment.

1.08 WARRANTY

A. Standard IPC Limited Lifetime Warranty against material and manufacturing defects.

PART 2 - PRODUCTS

2.01 MANUFACTURER

A. Acceptable Manufacturer: IPC Door and Wall Protection Systems, InPro Corporation, PO Box 406 Muskego, WI 53150 USA; Telephone: 800.222.5556, Fax: 888.715.8407, www.inprocorp.com

C. Provide all wall guards and wall protection from a single source.

2.02 MANUFACTURED UNITS

A. Wall Guard Profile

1. 1500i Infinity System Wall Guard, 5"(127mm) height x 1" (25mm) depth, and abbreviated aluminum retainer. Inner impact bumper, 1-7/8" (48mm) high.

2. 1500iW Infinity System Wall Guard, 5"(127mm) height x 1" (25mm) depth, and abbreviated aluminum retainer. Inner impact bumper, 1-7/8" (48mm) high. Wall guard shall have a full wrap woodgrain pattern. Black reveals for end caps and corners.

2.03 MATERIALS

A. Vinyl: Snap-on cover of .080"(2mm) thickness shall be extruded from chemical and stain resistant polyvinyl chloride with the addition of impact modifiers. Inner snap-on vinyl impact bumper of .070" (1.8mm) thickness shall be extruded from chemical and stain resistant polyvinyl chloride with the addition of impact modifier. No plasticizers shall be added (plasticizers may aid in bacterial growth).

B. Aluminum: 2"(51mm) aluminum retainer supports of .080" (2mm) thickness shall be fabricated from 6063-T5 aluminum, with a mill finish.

2.04 COMPONENTS

A. End caps, inside corners, outside corners and brackets shall be made of injection molded thermoplastics.

B. Molded reveals shall have a smooth finish and shall be black.

C. Impact Bumper: Continuous impact bumper shall be extruded from recycled polyvinyl chloride.

D. Fasteners: All mounting system accessories appropriate for substrates indicated on the drawings shall be provided.

2.05 FINISHES

A. Vinyl Covers: Colors of the wall guard to be selected by the architect from the IPC finish selection. Surface shall have a pebblette texture.

B. Inner Impact Bumper: Color of the inner impact bumper to be black.

C. Molded Components: End caps, inside corners, outside corners and brackets shall be of a color matching the wall guards. Surface shall have a pebblette texture.

PART 3 - EXECUTION

3.01 EXAMINATION

A. Examine areas and conditions in which the wall guard

systems will be installed.

1. Complete all finishing operations, including painting, before beginning installation of wall guard system materials.

B. Wall surface shall be dry and free from dirt, grease and loose paint.

3.02 PREPARATION

A. General: Prior to installation, clean substrate to remove dust, debris and loose particles.

3.03 INSTALLATION

A. General: Locate wall guard as indicated on the approved detail drawing for the appropriate substrate, and in compliance with the IPC installation instructions. Install wall guard, level and plumb at the height indicated on the drawings.

B. Installation of 1500i/1500iW Wall Guards:

1. Determine the height of the top of the wall guard above the finished floor. Deduct 2¹/₂" (63mm) and snap a chalk line at that height.

2. Use 6 aluminum retainer supports per 12' (3.66m) length, spaced 27" (686mm) on center. Mark the location of mounting holes on the chalk line. At the beginning and end of each run allow 1¹/₂" (38mm) for end caps, 1³/₁₆" (21mm) for outside corners, and 1⁷/₁₆" (37mm) for inside corners. Allow 1/16" (1.6mm) between end caps/corners and the aluminum retainer support in order to allow for adjustments when attaching the vinyl cover. NOTE: When mounting on concrete or brick, drill 1/4" (6mm) holes, 3/8" (9.5mm) from each end of the retainer at the correct centerline location for end caps or corners.

3. Drill 1/4" (6mm) holes at each mark. Position ALLIGATOR anchors into the holes on the wall and use #10 x 1³/₄" phillips pan head screw to attach each aluminum retainer support to the wall. Level and tighten the aluminum retainer supports to the wall.

4. (1500iW - Slide reveals onto end caps and corners.) Slide the end caps and corners onto the aluminum supports, leaving a 1/16" (1.5mm) gap for adjustments, and secure by using one 1-1/4" self-tapping screws per end cap or two per corner. NOTE: To mount on concrete or brick, use the #10 x 1³/₄" phillips pan head screws to secure end caps or corners.

5. Cut the vinyl impact bumper to the distance between the inside edge of end caps and corners. Position the vinyl impact bumper on the inner aluminum retainer guides at one end. Work to the other end by pushing the impact bumper over the aluminum guides until it snaps into place.

6. Cut the vinyl cover to the distance between the end caps and corners. NOTE: Trim all factory edges square before installation. Position the vinyl cover on the support assembly to check the fit. Adjust end caps and corners to obtain a tight fit. Position the vinyl cover on one end of the aluminum retainer supports and work to the other end by pushing the cover over the aluminum until it snaps into place.

3.04 CLEANING

A. At completion of the installation, clean surfaces in accordance with the IPC clean up and maintenance instructions.

Inprocorp.com • 800.222.5556 • 262.679.9010

World Headquarters S80 W18766 Apollo Drive, Muskego, WI 53150 USA

IPC™

DOOR + WALL PROTECTION SYSTEMS