

700/700W

Wall Guards



700



700W

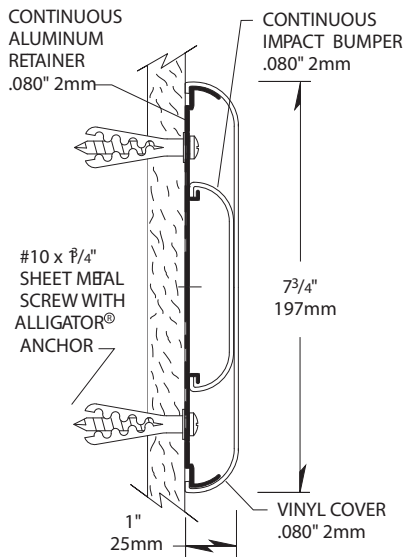

- 7 3/4" (197mm) of wall protection, extends 1" (25mm) from wall
- Optional rubber spacer extends an additional 1/2" (13mm) from wall
- Optional molded brackets can be installed to extend the 700 Wall Guard 1 7/8" (48mm) from the wall
- Mounted on a sturdy .080" (2mm) thick, continuous aluminum retainer
- .080" (2mm) thick, scratch and stain resistant rigid vinyl cover
- Easy installation, clean-up and maintenance
- Manufactured in 12' (3.66m) standard lengths
- All mounting fasteners are included with each order
- 700W Model – Manufactured with Woodland pattern full wrap and includes black reveals for end caps and corners
- Meets the most rigorous standards and criteria of chemical emissions as prescribed by the GREENGUARD Environmental Institute
- Has been tested and meets GREENGUARD Environmental Institute's and the state of California's requirements for low emitting products as tested by Air Quality Sciences
- Has been tested and meets the GREENGUARD Children & School chemical emissions levels



IPC.356/REV.9

700/700W Wall Guards

Suggested Specifications

PART 1 – GENERAL

1.01 SUMMARY

A. Wall guard system for wall protection and decoration

1.02 SECTION INCLUDES

A. 700/700W Wall Guard Systems

1.03 REFERENCES

A. American Society for Testing and Materials (ASTM)

B. National Building Code of Canada (NBC)

C. National Fire Protection Association (NFPA)

D. Society of Automotive Engineers (SAE)

E. Underwriters Laboratory (UL)

F. Underwriters Laboratory of Canada (ULC)

G. Uniform Building Code (UBC)

1.04 SYSTEM DESCRIPTION

A. Performance Requirements: Provide wall guard systems that conform to the following requirements of regulatory agencies and the quality control of IPC Door and Wall Protection Systems, InPro Corporation.

1. Fire Performance Characteristics: Provide UL Classified wall guards conforming with NFPA Class A fire rating. Surface burning characteristics, as determined by UL-723 (ASTM E-84), shall be flame spread of 10 and smoke development of 350 - 450. Provide ULC (Canada) listed wall guards conforming to the requirements of the National Building Code of Canada 2010, Subsection 3.1.13. Surface burning characteristics, as determined by CAN/ULC-S102.2, shall be flame spread of 15 and smoke developed of 35.

2. Self Extinguishing: Provide wall guards with a CC1 classification, as tested in accordance with the procedures specified in ASTM D-635-74, Standard Test Method for Rate of Burning and/or Extent and Time of Burning of Self-Supporting Plastics in a Horizontal Position, as referenced in UBC 52-4-1988.

3. Impact Strength: Provide rigid vinyl profile materials that have an Impact Strength of 30.2 ft-lbs/inch of thickness as tested in accordance with the procedures specified in ASTM D-256-90b, Impact Resistance of Plastics.

4. System Impact Resistance: Provide a wall guard system that resists an impact of 175.9 ft-lbs while producing no visual blemishes upon the vinyl cover surface and no deformations in the aluminum retainers, as tested in accordance with applicable provisions of ASTM F 476-84, paragraph 18, Impact Test.

5. GREENGUARD Certified: Provide GREENGUARD Certified material. Profiles shall meet the requirements of GREENGUARD Certification Standards for Low-Emitting Products and GREENGUARD Product Emission Standard for Children & Schools.

6. Chemical and Stain Resistance: Provide wall guards that show resistance to stain when tested in accordance with applicable provisions of ASTM D-543.

7. Fungal and Bacterial Resistance: Provide rigid vinyl that does not support fungal or bacterial growth as tested in accordance with ASTM G-21 and ASTM G-22.

8. Color Consistency: Provide components matched in accordance with SAE J-1545 - (Delta E) with a color difference no greater than 1.0 units using CIE Lab, CIE CMC, CIE LCh, Hunter Lab or similar color space scale systems.

1.05 SUBMITTALS

A. Product Data: Manufacturer's printed product data for each type of wall guard specified.

B. Detail Drawings: Mounting details with the appropriate fasteners for specific project substrates.

C. Samples: Verification samples of wall guard, 8" (203mm) long, in full size profiles of each type and color indicated.

D. Manufacturer's Installation Instruction: Printed installation instructions for each wall guard.

1.06 DELIVERY, STORAGE AND HANDLING

A. Deliver materials in unopened factory packaging to the jobsite

B. Inspect materials at delivery to assure that specified products have been received.

C. Store in original packaging in a climate controlled location away from direct sunlight.

1.07 PROJECT CONDITIONS

A. Environmental Requirements: Products must be installed in an interior climate controlled environment.

1.08 WARRANTY

A. Standard IPC Limited Lifetime Warranty against material and manufacturing defects.

PART 2 – PRODUCTS

2.01 MANUFACTURER

A. Acceptable Manufacturer: IPC Door and Wall Protection Systems, InPro Corporation, PO Box 406 Muskego, WI 53150 USA; Telephone: 800.222.5556, Fax: 888.715.8407, www.inprocorp.com

B. Substitutions: Not permitted

C. Provide all wall guards and wall protection from a single source.

2.02 MANUFACTURED UNITS

A. Wall Guard Profile

1. 700 Wall Guard, 7³/₄" (197mm) height x 1" (25mm) depth, with continuous aluminum retainer.

2. 700W Wall Guard, 7³/₄" (197mm) height x 1" (25mm) depth, with continuous aluminum retainer. Wall guard has a full wrap woodgrain pattern. Black reveals for end caps and corners.

3. Options: Curved wall guard, specify radius. Minimum radius – 3 feet (.91m)

2.03 MATERIALS

A. Vinyl: Snap on cover of .080" (2mm) thickness shall be extruded from chemical and stain resistant polyvinyl chloride with the addition of impact modifiers. No plasticizers shall be added (plasticizers may aid in bacterial growth).

B. Aluminum: Continuous aluminum retainer of .080" (2mm) thickness shall be fabricated from 6063-T5 aluminum, with a mill finish.

2.04 COMPONENTS

A. End caps, outside corners, inside corners and brackets shall be made of injection molded thermoplastics.

B. Molded reveals shall have a smooth finish and shall

be black.

C. Fasteners: All mounting system accessories appropriate for substrates indicated on the drawings shall be provided.

2.05 FINISHES

A. Vinyl Covers: Colors of the wall guard to be selected by the architect from the IPC finish selection. Surface shall have a pebblette texture.

B. Molded Components: End caps, outside corners, inside corners and brackets shall be of a color matching the wall guards. Surface shall have a pebblette texture.

PART 3 – EXECUTION

3.01 EXAMINATION

A. Examine areas and conditions in which the wall guard systems will be installed.

1. Complete all finishing operations, including painting, before beginning installation of wall guard system materials.

B. Wall surface shall be dry and free from dirt, grease and loose paint.

3.02 PREPARATION

A. General: Prior to installation, clean substrate to remove dust, debris and loose particles.

3.03 INSTALLATION

A. General: Locate the wall guard as indicated on the approved detail drawing for the appropriate substrate and in compliance with the IPC installation instructions. Install level and plumb at the height indicated on the drawings.

B. Installation of 700/700W Wall Guards:

1. Cut the aluminum retainer to the desired length, allowing 1⁹/₁₆" (40mm) for each end cap, 7⁷/₁₆" (11mm) for each outside corner and 1⁹/₁₆" (40mm) for each inside corner.

2. Drill 1/4" (6mm) holes in the aluminum retainer, 4" (102mm) from each end and evenly in a "zigzag" pattern. (10 anchors per 12' (3.66m) length).

3. Position and level the aluminum retainer on the wall, allowing for end caps and corners, and transfer mounting holes to the wall with a marker. Drill 1/4" (6mm) holes at each mark and position ALLIGATOR anchors into the holes on the wall. Mount the retainer with #10 x 1³/₄" phillips pan head screws and tighten the screws to secure the retainer.

4. (700W - Slide reveals onto end caps and corners.) Slide the end caps and corners onto the aluminum, leaving a 1¹/₁₆" gap for adjustments, and secure with two 1¹/₄" self-tapping screws per end cap or four per corner.

5. Cut the vinyl cover to the distance between the end caps/corners. NOTE: Trim all factory edges square before installation. Position the vinyl cover on the aluminum retainer starting at one end and working to the other end by pushing the cover over the aluminum until it snaps into place.

3.04 CLEANING

A. At completion of the installation, clean surfaces in accordance with the IPC clean-up and maintenance instructions.

Inprocorp.com • 800.222.5556 • 262.679.9010

World Headquarters S80 W18766 Apollo Drive, Muskego, WI 53150 USA

IPC®

DOOR + WALL PROTECTION SYSTEMS
A DIVISION OF INPRO®