

# Installation Instructions

## 500/G2-500 Wall Guard

FIG. 1

Please read all instructions before installing wall guard.

1. Cut aluminum retainer to desired length, leaving allowance for end caps, inside corners and outside corners. See Figure 1.

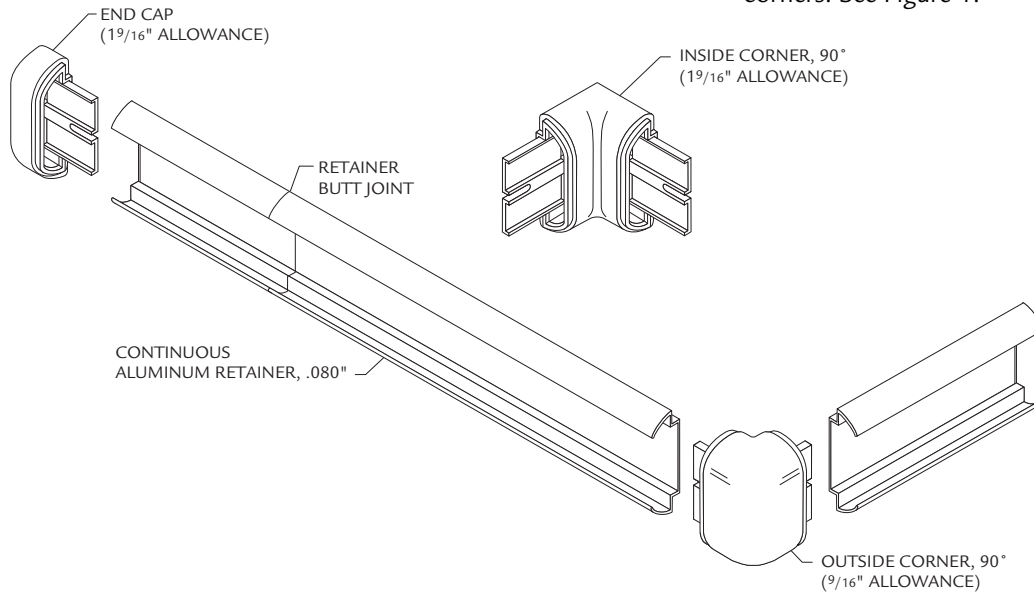
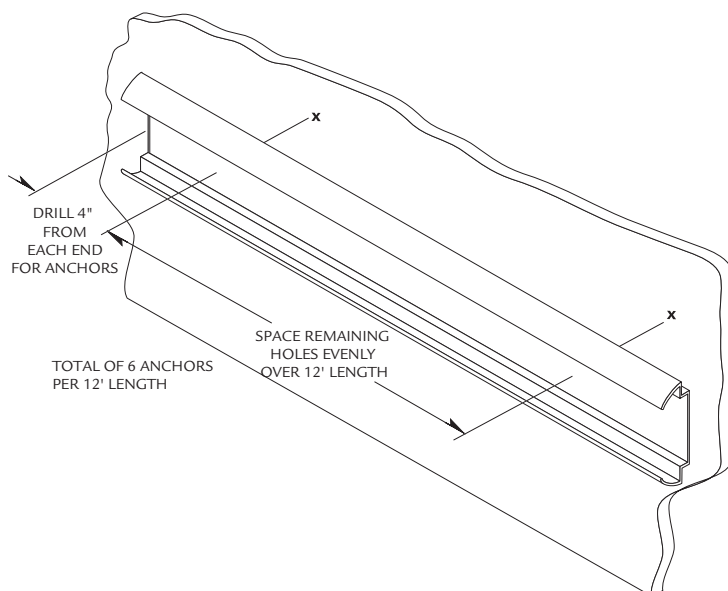

FIG. 2

2. Drill holes in centerline of retainer using 1/4" drill bit. Position retainer on wall allowing for end caps/corners. Level and mark holes. See Figure 2.

NOTE: For concrete or brick wall installation, drill 1/4" holes, 3/8" from each end of retainer for end caps/corners.



IPC.341/REV.6



# Installation Instructions

## 500/G2-500 Wall Guard

FIG. 3

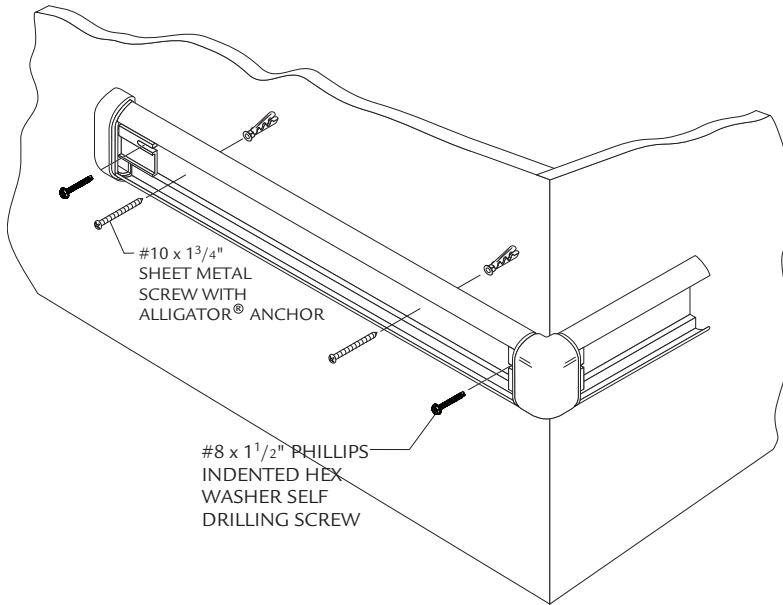

3. Drill marked holes on wall using a 1/4" drill bit and position Alligator anchors into holes. Mount retainer on wall and tighten screws to secure. Slide end caps and corners onto the retainer and secure, leaving a 1/16" gap between end caps/corners and retainer to allow for adjustment. See Figure 3.

NOTE: If rubber spacers are used, attach them behind the retainer at all mounting hole locations including those for end caps and corners.

NOTE: For concrete or brick wall installation, use #10 x 1 3/4" Phillips pan head screws to secure end caps and corners.

FIG. 4

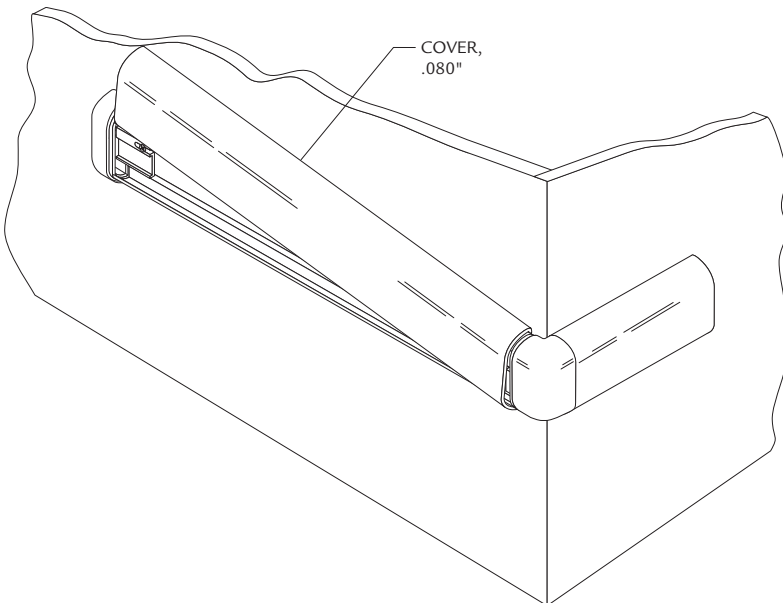

4. Cut the cover to length between end caps and/or corners. (Note: Trim factory edges square before installation). Position cover on retainer and adjust end caps and/or corners for a tight fit. Starting at one end, push cover onto retainer until it snaps into place. See Figure 4.

